

KRUGMANN 7 Day Wireless Chronostats

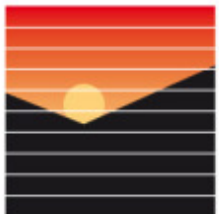

Technical information and installation instructions

KRUGMANN



RVR
Energy Technology Experts

Version 20090917

Table of Contents

Page	Title
3	1. Preface and Introduction
3	1.1 How the controls work
3	1.2 KC7CH Central Heating Controller
3	1.3 KC7DHW Water Heating Controller
4	1.4 Multiple Zones
4	1.5 Example System
5	2. The Controller
5	2.1 Modes of Operation
6	3. Installation
6	3.1 Install the receivers
6	3.2 Pair the receivers to the controller
7	3.3 Mount the controller
7	4. Initial controller set up
7	4.1 Set the time and day
8	4.2 Set the default temperature settings
8	4.3 Creating an automatic programme
9	4.4 Setting the “OFF” Behaviour
9	4.5 Optional: Setting the differential
9	4.6 Optional: Adjustment and calibration of temperature
10	5. Using the controller day to day
10	5.1 Automatic mode
11	5.2 Manual mode
11	5.3 Antifreeze mode
11	5.4 Off mode
11	6 Power supply and batteries
12	Product Specifications

1.0 PREFACE AND INTRODUCTION

The Krugmann KC7 series are wireless 7 day programmable time and temperature controllers. Two versions are available. The KC7CH is suitable for controlling central heating zones and the KC7DHW is designed to control domestic water heating zones.

Both the KC7CH and KC7DHW can also be used to provide boiler interlock.

1.1 How the controls work

The Krugmann wireless system typically consists of a controller and two (or more) receivers. The controller "talks" to the receivers via Radio Frequency.



The controller is mounted anywhere within the central heating zone (or next to the water heating tank) and a receiver is mounted next to the zone valve or pump.

A second receiver may be mounted next to the boiler to provide boiler interlock.

When the controller activates and calls for heat, the first receiver will open the zone valve and the second receiver will activate the boiler. Up to 5 receivers may be paired to each controller (e.g. extra receivers can be used to activate circulating pumps or other items)

1.2 KC7CH Central Heating Controller

The KC7CH is a Central Heating Controller. It has a built in thermostat which measures the air temperature surrounding the controller. It is used to control the air temperature of a zone, allowing temperatures up to a maximum of 30° C.

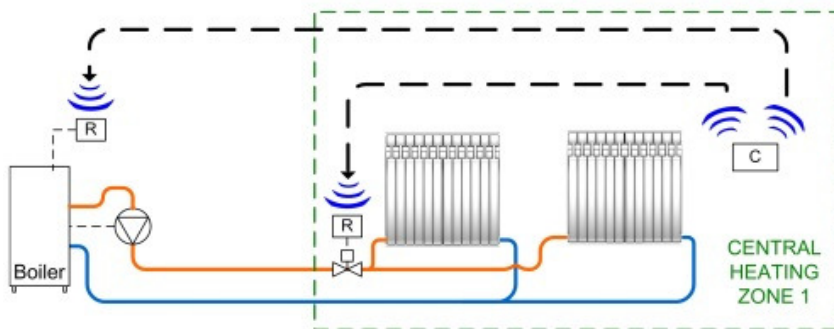

Figure 1: Using a KC7CH controller to control a central heating zone

1.3 KC7DHW Water Heating Controller

The KC7DHW is a Water Heating Controller. It has an external temperature sensor which must be mounted to the water heating tank. This controls the temperature of the domestic hot water stored in the tank, allowing temperatures up to a maximum of 70° C.

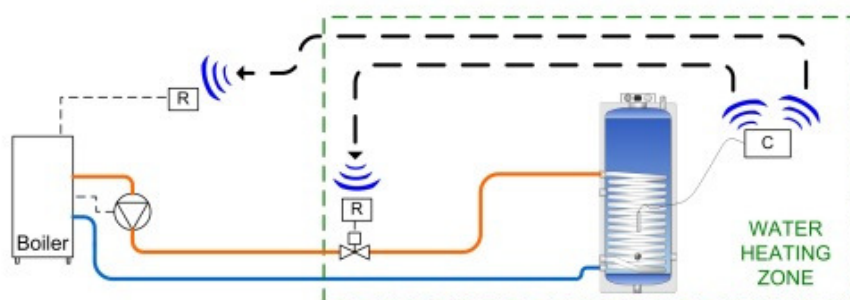

Figure 2: Using a KC7DHW controller to control a water heating zone

1.4 Multiple zones

The Krugmann KC7 range may be used to control multiple zones in a building.

Each zone may be controlled by a separate controller and set of receivers.

Where multiple zones are used, the receivers mounted next to the boiler are wired in parallel so that any single zone turning on a receiver will call the boiler to fire.

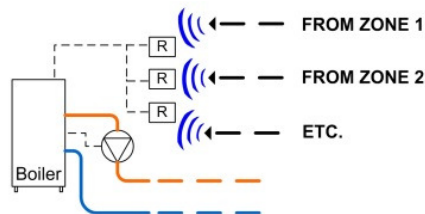

Figure 3: Boiler interlock with multiple zones

1.5 Example system

A typical example is a house with two central heating zones and a water heating zone.

This house may be fully controlled with boiler interlock using two KC7CH controllers, one KC7DHW controller and six receivers.

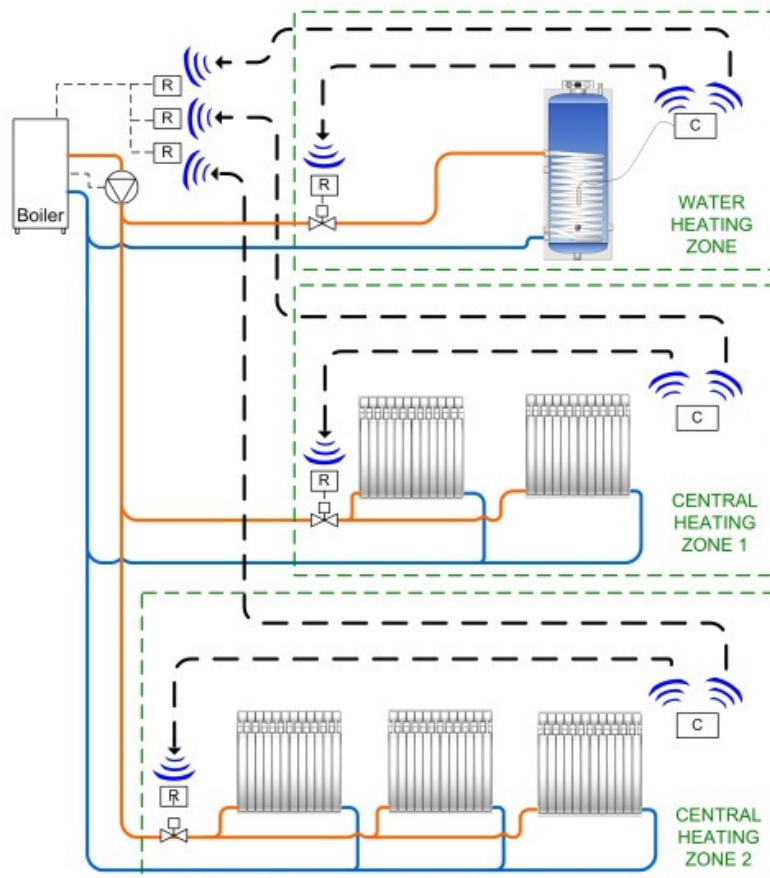

Figure 4: Example—controlling two CH zones and a DHW zone using the Krugmann KC7 range

2.0 The controller

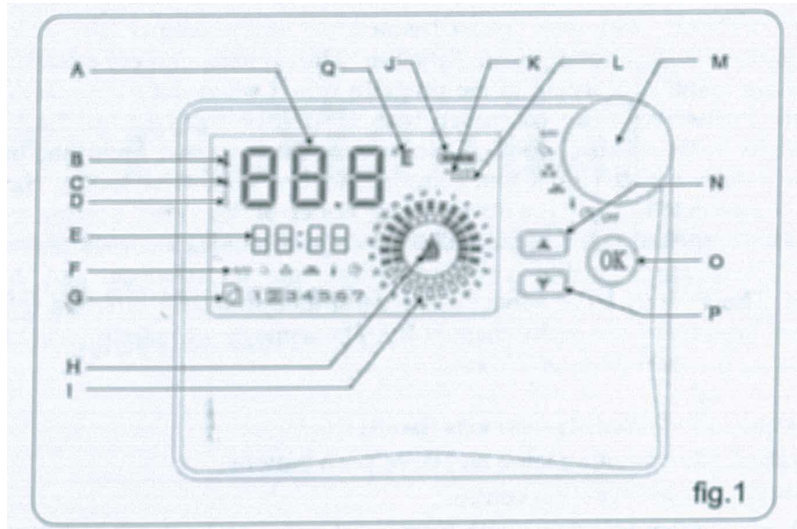









Figure 5: Controller display

- A= Current Temperature
- B= Comfort Temperature programme activated
- C= Economic Temperature programme activated
- D= Anti-Freeze programme activated
- E= Current Time
- F= Current Mode of operation
- G= Day of week (current day highlighted)
- H= Heating on (flame displayed) / Heating off (no flame)
- I= Programme display—hour by hour settings for current day
- J= Battery indicator
- K= Adjust controller sensitivity mode
- L= Copy program indicator
- Q= Celsius degree or Fahrenheit degree indicator
- N= ▲ increase or up key
- O= OK “confirmation” key
- P= ▼ decrease or down key
- M= Mode of operation selection click wheel

2.1 Controller / Modes of operation

The Krugmann KC7 range has 7 modes of operation.

Mode and Symbol	Description
Automatic operation mode 	Controller automatically heats according to pre-set user settings
Manual operation mode 	User can manually control temperature using up and down buttons
Antifreeze mode 	Heating off—Controller only provides antifreeze protection for pipes
Manual program setting mode 	Allows the user to set heating level for any hour of the week
Temperature setting mode 	Allows the user to set Comfort, Economic and antifreeze temperatures
Date/time setting mode 	Allows the user to set time and day of week
Switch off mode 	Turns the controller off*

*Installer must set “Switch off” operation mode at time of installation. In this mode the controller switches off but the heating zone will remain in one of three pre-chosen modes: 1. Heating AUTO / 2. Heating OFF / 3. Antifreeze mode. See page 9 for details.

3.0 Installation

WARNING! This appliance must be installed by a competent and qualified person, in accordance with relevant clauses of applicable standards and recommendations. These include but may not be limited to the following:-

IEE Wiring Regulations
 Health & Safety legislation
 All relevant Building Regulations.
 I.S. 813 Domestic Gas Installations
 I.S. 820 Non-Domestic Gas Installations

3.1. Install the receivers

Receivers must only be installed by professionals as they must be connected to a 230V power supply. Extreme care must be exercised when installing as there is a risk of electrocution.

The receiver should be mounted in-line to the power supply of the zone valve, boiler, etc. When the controller calls for heat, the relay in the receiver closes and this causes the motorised valve / boiler / pump to activate.

Where multiple receivers are mounted to a single device (e.g. for boiler interlock) they should be installed in parallel to allow any single receiver to activate the attached device.

To install the receiver box, remove the cover and mount the box firmly to the wall / or other surface. Then wire the power supply.

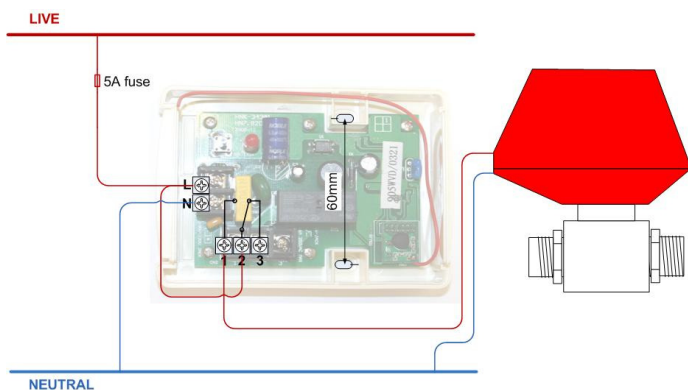

Figure 6.1: Switching of zone valve or pump

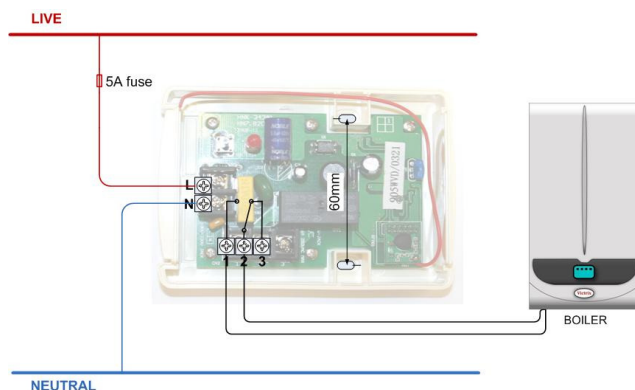

Figure 6.1: Volt free boiler interlock

3.2. Pair the receivers to the controller

To pair a receiver with a controller, press the button inside the receiver (the cover must be off the receiver). The light in the receiver will begin to flash. It is now ready for pairing.

Turn the controller to the OFF setting. Then press and hold the UP and DOWN buttons for five seconds. The flashing light on the receiver will disappear and the receiver will then be paired to the controller.

It is possible to test this by putting the controller in manual mode. Increase the temperature using the UP button until the required temperature is higher than the ambient temperature. The receiver should activate (red light turns on in the receiver)

Reduce the temperature using the DOWN button on the controller. The receiver should turn off once the required temperature is lower than the ambient temperature.

- 6 If the receiver responds as required then pairing is complete. Put the cover back on the receiver.

3.3 Mount the controller

KC7CH Central heating controller:

The controller should be mounted in an area of the house that is heated by the zone. Good locations would be: Dining room / Living room / Master bedroom / etc. Rooms with other heat sources such as the kitchen or a sitting room with a fire or stove should be avoided.

The controller should not be installed in direct sunlight or near radiators or other heat sources. Doing so may affect operation as the temperature readings may be incorrect.

The installation height should be approximately 1.5m off the floor.

KC7DHW Water heating controller:

The controller should be mounted near to the water heating tank.

The external temperature sensor should be mounted approximately half way down the tank. The sensor should be mounted inside the insulation. On tanks with hard foam insulation, a small hole should be made in the insulation in order to allow the sensor to be inserted in direct contact with the tank.

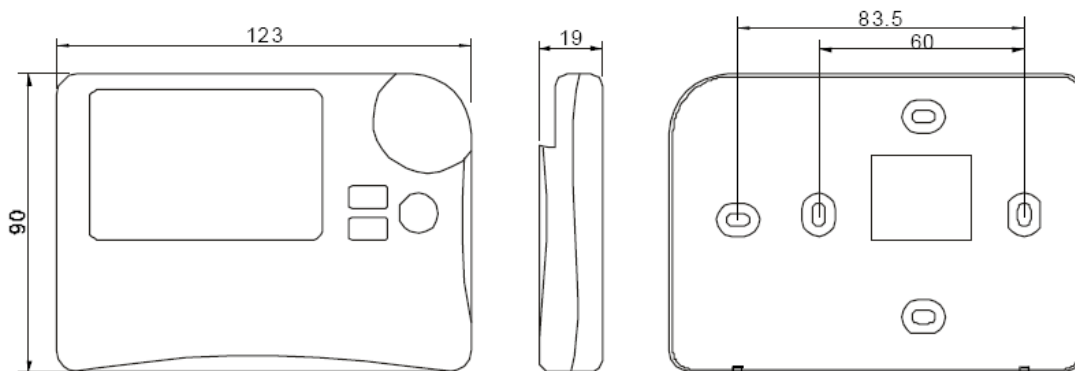



Figure 7: Controller Dimensions

4.0 Initial Controller Set Up

4.1. Set the time and day

Turn the click wheel clockwise until the unit is in Date/Time setting mode: 

The day indicator will be flashing. Press the UP or DOWN buttons to select the day of the week.

1=Monday, 2=Tuesday, ...7 = Sunday.

Once the day of the week is selected press OK. This will enter Time setting mode. Press UP or DOWN to set the hour (24 hour clock). Press OK. Press UP or DOWN to set the minute. Press OK to finish setting the time.

4.2 Set the default temperature settings

Turn the click wheel clockwise until the unit is in default temperature setting mode: 

Under programmed operation the controller can keep the zone at one of three temperature settings.

Comfort temperature: The standard temperature you would like the zone to be when in the house. Typically 20°C

Economic temperature (also known as set back temperature): A lower temperature you can set at night or when in and out of the house etc. Typically 10-12°C

Anti-freeze temperature: A very low (4 or 5 degrees) temperature which stops pipes from freezing when the house is unoccupied. Typically 4°C

The temperature indicator will be flashing. Press the UP or DOWN buttons to select the desired **COMFORT** temperature. Press OK when you have selected a temperature.

The temperature indicator will flash again. Press the UP or DOWN buttons to select the desired **ECONOMICAL** temperature. Press OK when you have selected a temperature.

The temperature indicator will be flashing. Press the UP or DOWN buttons to select the desired **ANTI-FREEZE** temperature. Press OK when you have selected a temperature.

Once you have entered all three temperatures they are automatically saved.

Please note—for the KC7DHW it is important to bring the temperature in the tank to 60°C once a day. This is to prevent legionella. This can be done by setting the COMFORT setting to 60°C and ensuring the programme created under section 4.3 is set to COMFORT for at least one time segment in every day.

4.3 Creating an automatic program

The Krugmann KC7 Range is fully programmable. The units let you choose when the unit will maintain the COMFORTABLE, ECONOMIC and ANTI FREEZE temperatures at any time during the week in one hour segments.



Turn the click wheel clockwise until the unit is in Programme setting mode:

The day indicator will be flashing. Press the UP or DOWN buttons to select the day of the week you wish to programme.

1=Monday, 2=Tuesday, ...7 = Sunday.

Please note—It is a good idea to start with Monday as you can quickly copy this programme to the other weekdays after.

Once the day of the week is selected press OK. This will enter programme setting mode for that day.

The segment “0-1” will begin flashing on the programme display.

Press UP or down to select between the three temperatures:

Two Bars: COMFORT temperature setting

One Bar: ECONOMIC temperature setting

Alternating bars flashing: ANTIFREEZE temperature setting

Once you have chosen your desired temperature setting for 00:00 AM—1:00 AM, press OK. This will move to the next segment, “1-2” which will allow you to set the temperature setting for 1:00AM to 2:00 AM.

Repeat the steps above to set the desired temperatures for the 24 hour period. If at any stage you want to save the program without having to set every segment, simply hold OK for 5 seconds and you will return to the day selection.

COPYING PROGRAMMES BETWEEN DAYS

If you wish to copy a programme between days (e.g. you have created a good programme for Monday and wish to copy it to Tuesday) then do the following:

Select the day you wish to copy using the UP / DOWN buttons
 Press and hold OK for 5 seconds, until “COPY” appears on the screen. Do not release the OK button.
 With the OK button held, press up or down to select the day you wish to copy to. Release the OK button.

4.4 Setting “OFF” behaviour

You must set the “Switch off” operation mode at time of installation.

This controls how the controller works when switched to the “Off” position.

To set this, turn the click wheel to “OFF” mode. Press OK for five seconds and do not release it.

Press UP or DOWN buttons to choose a setting for the “Off” mode:

ON—Controller switches to standby and continues to function in automatic mode
 PF—Controller switches to standby and maintains minimum antifreeze protection
 OF—Controller switches off and turns the zone off.

Once you have chosen a mode release OK to save the settings.

4.5 Optional: Setting the differential

Under operation, the system is designed to turn the zone ON as soon as the ambient temperature drops below the desired temperature. The default is to switch off again after an increase of 1.5°C.

E.g. Desired temperature: 21°C. Temperature drops to 20.5°C. The controller turns the zone ON and does not switch it off until the ambient temperature is 22°C.

This default setting offers a good degree of precision (to within 1 degree of the user’s desired temperature) and also reduces boiler cycling on/off, leading to better fuel efficiency.

If the user desires, they may adjust the differential temperature between 0.5°C and 3°C in steps of 0.5°C.

Please note, 1.5 degrees is a good setting for most applications!

To adjust the differential temperature, set the controller mode to MANUAL. Press OK for 5 seconds until “ADJUST” appears on the screen. Press UP or DOWN to select the desired differential temperature and release OK to save the setting.

4.6 Optional: Adjustment and calibration of the temperature

It is possible if required to calibrate the readings internal  temperature sensor up or down.

Turn the click wheel until the unit is in Antifreeze mode:

Press and hold OK for 3 seconds. Do not release the OK button.

Press UP or DOWN to adjust the reading from the internal sensor between -3.0°C and +3.0°C

Release the OK button to save the new settings.

5.0 Using the controller day to day

There are four useful modes for the end user

5.1. Automatic mode

Turn the click wheel until the unit is in Auto mode: 

In this mode the controller is fully automatic and will run according to the programme entered during initial set-up.

The current ambient temperature is displayed on-screen. If the zone is currently being heated there will be a flame flickering in the centre of the circular programme display. If the zone does not require extra heat (e.g. ambient temperature is at or above desired temperature) then there will be no flame in the centre of the circular programme display.

Press UP or DOWN to view the current desired temperature as set in the programme. If you wish to override this until the next time the controller enters a different programme setting, simply press UP or DOWN to choose the desired temperature. Once the controller enters a time segment with a different temperature preset, the controller will revert to normal programmed operation.

NOTE

When you turn on the controller for the first time, it has a factory pre-set programme activated. This is denoted by the Auto symbol without the additional Manual Programme Setting indicator, E.G.



When you alter the Manual Programme via the Manual programme setting mode, the AUTO mode instantly turns on the manual programme. This is denoted by the symbols below on-screen:



To switch between factory pre-set programme and Manual programme at any time just press and hold OK for 5 seconds on the Auto screen.

The factory pre-set programme is as follows:

From Monday to Friday:

00:00.....06:00 Economical temperature
 06:00.....08:00 Comfort temperature
 08:00.....18:00 Antifreeze temperature
 18:00.....22:00 Comfort temperature
 22:00.....24:00 Economical temperature

Saturday and Sunday:

00:00.....06:00 Economical temperature
 06:00.....22:00 Comfort temperature
 22:00.....24:00 Economical temperature

5.2. Manual mode

Turn the click wheel until the unit is in Manual mode: 

In this mode you can set the temperature manually. Simply press the UP or DOWN buttons to select the desired temperature. The temperature flashes while you choose your desired temperature. After 5 seconds, the temperature will stop flashing, will save your desired setting, and return to displaying the ambient temperature.

The controller will maintain this desired temperature indefinitely until switched to a different mode of operation.

5.3. Antifreeze mode

Turn the click wheel until the unit is in Antifreeze mode: 

Antifreeze mode is a very useful mode. In this mode the controller will keep the zone at a minimum temperature to prevent freezing of the pipes. It can be used when away from the house for long periods in winter.

It is also useful in summertime as the unit can be set to antifreeze mode—this will keep the ambient temperature and time display on-screen, but without any heating active.

5.4. Off mode

Turn the click wheel until the unit is in off mode: **OFF**

This turns the controller off. Please see section 4.4 for further information about off behaviour.

6.0 Power supply and batteries

It is possible to run the unit using either 2 x AA batteries or a 4V DC power supply. Most users will choose to use the batteries due to the low power consumption of the controller and ease of mounting when no power supply is used.

To replace the batteries, carefully slide a small screwdriver under the lip on top of the controller and pop the front out on both sides. Replace the batteries, and click the front of the controller back up into place.

WARNING! REMOVING THE BATTERIES WILL CAUSE THE CONTROLLER TO LOSE ITS SETTINGS AND REVERT TO FACTORY DEFAULTS. DO NOT REMOVE THE BATTERIES UNLESS ABSOLUTELY NECESSARY!

KRUGMANN KC7 RANGE—Product Specifications

Power Supply: 2 no LR6 AA type 1.5v alkaline batteries. Battery life over 1 year in normal operation.

Temperature adjustment range: 4-30°C (KC7CH), 4-70°C (KC7DHW)

Ambient temperature displayed on the screen: 0-40°C

Temperature test frequency: once per minute.

Display accuracy: to within 0.5°C

Probe: NTC 3%

Protection degree: IP20

Thermal gradient: IK/3min

Output: Switch relay

Load on contacts: 16A/250V

Insulation conditions: Indoors only

Max. operating temperature: 50°C ambient air temperature

Storage temperature: between 0-60°C

Frequency : 433 MHz

Programming: 7 day, time and temperature

LCD display

Minimum programming interval: 1 hour

Installation: Wall mounted

Radio transmission distance: Indoor up to 25m

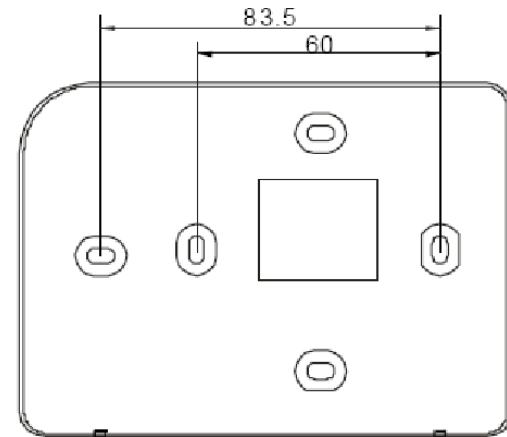
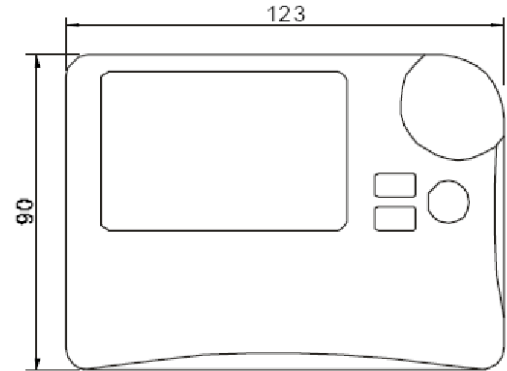

Conformity with Standard:

EN 60730-1 and its revision

EN 60730-2-7

EN 60730-2-9

Conformity with European Decrees:

B. T. 73/23/EEC

E. M. c. 89/336/EEC and Amendments 93/68/EEC

Supplier details:

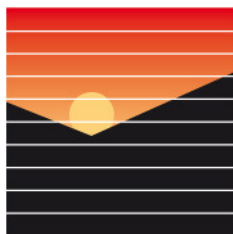

RVR
Energy Technology Experts

RVR Energy Technology Limited • Kenmare, Co. Kerry, Ireland

0818 313 003 (ROI) • 020 3287 0130 (UK) • +353 64 6641344 (INT.)

www.rvr.ie • www.rvr.co.uk